



昌 勃 股 份 有 限 公 司
Dr. POWER CORPORATION

零 件 規 格 書/承 認 書

SPECIFICATION FOR APPROVAL

CUSTOMER : 安研科技股份有限公司

DESCRIPTION : LiFePO4 PACK, 12.8V/22Ah

MODEL : 4S4P, 32650-5.5Ah

CUSTOMER PART NO : _____

APPROVED SIGNATURES

--	--	--	--

Rev	Date	Description	Designed	Checked	Approved
A	2021.3.30	LiFePO4 PACK 12.8V/22Ah		Eddie	Nelson

臺北市北投區吉利街 131 號 3 樓

3F, NO. 131, JILI ST., PEITOU, TAIPEI, TAIWAN, R.O.C.

TEL : 886-2-2820-7419 · FAX : 886-2-2827-0348



一、產品說明

鋰電池組：磷酸鋰鐵 4 串 4 併

電池芯款式：32650-5500mAh

IC：TI BQ40Z50RSMT-R1

電池組中包括用於 4 系列鋰離子電池的 BMS，可測量並保持鋰離子電池中可用容量，電壓，電流，溫度和其他關鍵參數的準確記錄，並通過 Modbus 兼容接口將此信息報告給系統主機控制器。

二、電池組規格

項目		規格	單位	註記
額定容量		22000	mAh	
常態電壓		12.8	V	
充電電壓		14.6 max	V	
標準充電電流		2	A	
標準放電電流		2	A	
放電截止電壓		8	V	
內阻值		≤50	mOhm	
重量		2.5±1.0	Kg	
操作溫度範圍	充電	0 ~ 60	°C	
	放電	-10~ 60	°C	
儲存溫度條件	低於一個月	-20 ~ 45	°C	Percentage of recoverable capacity 80%
	低於三個月	-20 ~ 35	°C	
	低於一年	-20 ~ 45	°C	
使用壽命		≥1000	cycle	充放電循環 1000 次之後, ≥70%容量



三、保護電路規格

No.	Item	Spec.	Unit	Remark
1	過充電壓偵測	3.7	V	
2	過充電壓保護解除	3.5	V	
3	過放壓偵測	2.0	V	
4	過放電壓保護解除	2.1	V	
5	放電電流保護偵測 (1)	5	A	
6	放電電流保護延遲時間 (1)	2	sec	
7	放電電流保護偵測 (2)	10	A	
8	放電電流保護延遲時間 (2)	1	Sec	
9	放電電流保護偵測 (3)	20	A	
10	放電電流保護延遲時間 (3)	31	mSec	
11	短路保護偵測(1)	50	A	
12	短路保護延遲時間 (1)	244	uSec	
15	充電電流保護偵測 (1)	10	A	
16	充電電流保護延遲時間 (1)	2	Sec	
17	充電電流保護偵測 (2)	12	A	
18	充電電流保護延遲時間 (2)	1	Sec	
13	短路保護偵測(2)	100	A	
14	短路保護延遲時間 (2)	122	uSec	
19	充電溫度保護	≤ 0 or ≥ 45	$^{\circ}\text{C}$	
20	充電溫度保護解除	≥ 5 or ≤ 40	$^{\circ}\text{C}$	
21	放電溫度保護	≤ -10 or ≥ 60	$^{\circ}\text{C}$	
22	放電溫度保護解除	≥ -5 or ≤ 55	$^{\circ}\text{C}$	
23	平衡電流	10	mA	



四、充電電路規格

項目	規格	單位	註記
充電電壓	14.6 max	V	
充電電流	2	A	
充電電截止電流	150	mA	
預充電流	150	mA	



五、通訊規格

■ Interface : RS-485 (Modbus)

■ Default Baud Rate : 19200 bps

■ Protocol

For example:

//BQ_SBSCmd_0x03_BatteryMode	=>	MODBUS Address = 0x00,0x01
//BQ_SBSCmd_0x08_Temperature	=>	MODBUS Address = 0x02,0x03
//BQ_SBSCmd_0x09_Voltage	=>	MODBUS Address = 0x04,0x05
//BQ_SBSCmd_0x0A_Current	=>	MODBUS Address = 0x06,0x07
//BQ_SBSCmd_0x0B_AverageCurrent;	=>	MODBUS Address = 0x08,0x09
//BQ_SBSCmd_0x0D_RelativeStateOfCharge;=>		MODBUS Address = 0x0a,0x0b
//BQ_SBSCmd_0x0E_AbsoluteStateOfCharge;=>		MODBUS Address = 0x0c,0x0d
//BQ_SBSCmd_0x16_BatteryStatus;=>		MODBUS Address = 0x0e,0x0f
//BQ_SBSCmd_0x17_CycleCount;=>		MODBUS Address = 0x10,0x11
//BQ_SBSCmd_0x18_DesignCapacity;=>		MODBUS Address = 0x12,0x13
//BQ_SBSCmd_0x19_DesignVoltage;=>		MODBUS Address = 0x14,0x15
//BQ_SBSCmd_0x1C_SerialNumber;=>		MODBUS Address = 0x16,0x17
//BQ_SBSCmd_0x3C_Cell_Voltage_4;=>		MODBUS Address = 0x1e,0x1f
//BQ_SBSCmd_0x3D_Cell_Voltage_3;=>		MODBUS Address = 0x20,0x21
//BQ_SBSCmd_0x3E_Cell_Voltage_2;=>		MODBUS Address = 0x22,0x23
//BQ_SBSCmd_0x3F_Cell_Voltage_1;=>		MODBUS Address = 0x24,0x25

Master 詢問 RTU 封包 (Query)						
Slave 地址	功能碼	起始地址高位	MODBUS Address	暫存器高位	讀取資料數 word	CRC
11H	03H	00H	6BH	00H	03H	76H 87H



六、外觀尺寸圖

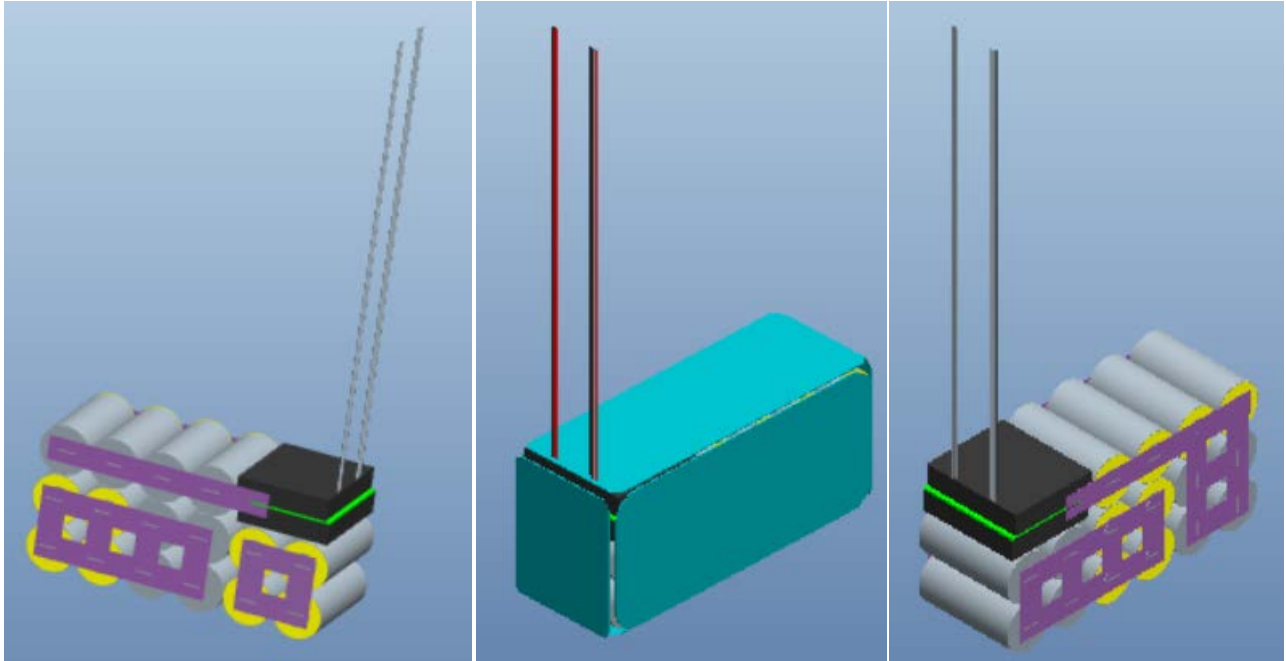

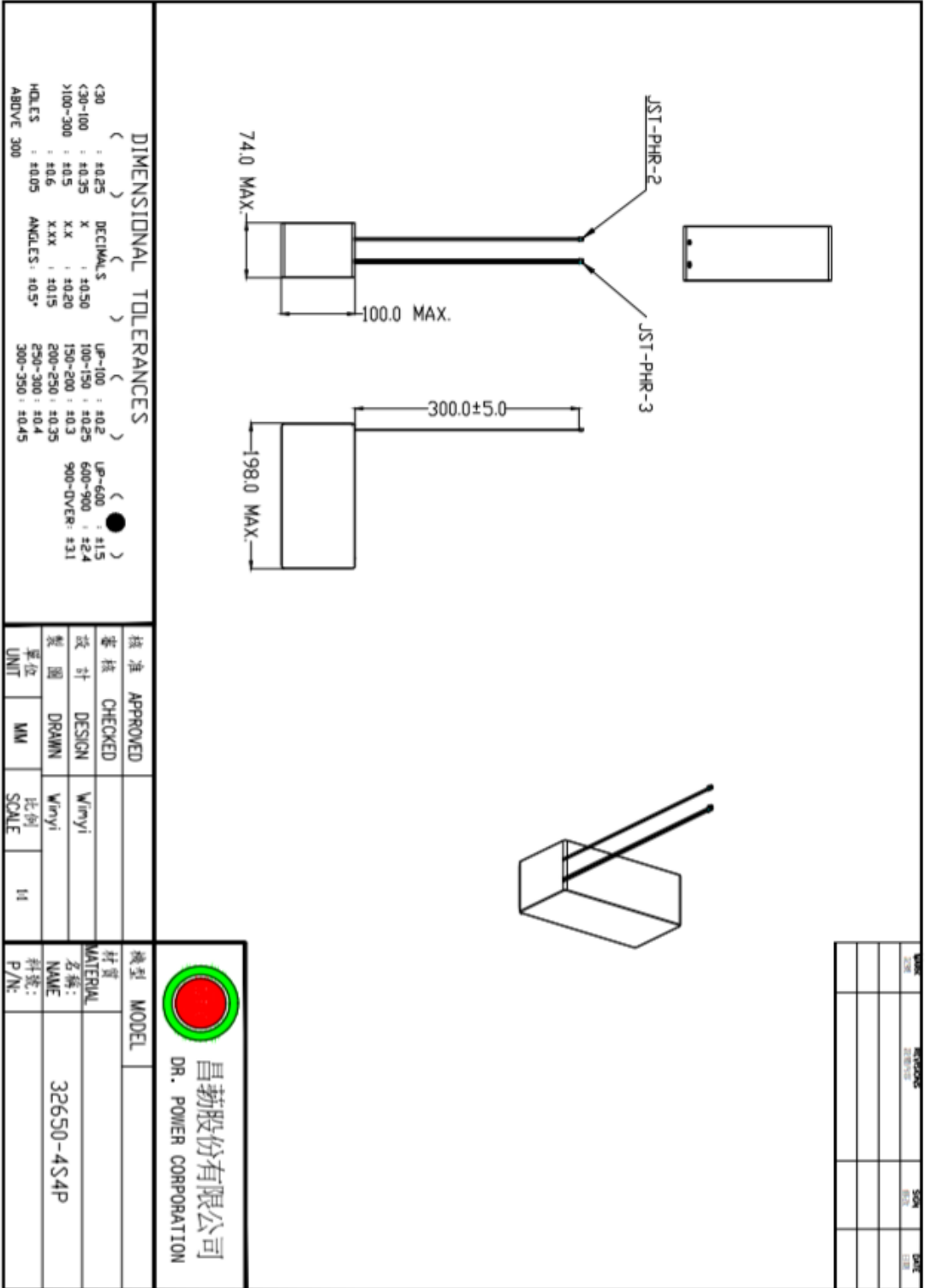



昌 勑 股 份 有 限 公 司
Dr. POWER CORPORATION

七、電池芯規格 (如附件)

锂离子电池规格书

Specification of Product for Lithium-ion Rechargeable Cell

客户名称 _____

产品名称 磷酸铁锂电池 LiFePO₄ battery

产品型号 32650-5500mAh

执行标准 GB/T18287-2013

客户承认

编 制	核 准	日 期
		2017.7.9

目录

Content

1. 适用范围 Scope.....	3
2. 产品型号 Model.....	3
3. 引用标准 Reference standard.....	3
4. 产品规格 Specification.....	3
5. 电芯的性能标准 Battery Cell Performance Criteria.....	3
6. 环境适应性 Environment Characteristics.....	4
7. 安全性能 Safety Characteristics.....	4
8. 标准测试条件 Standard Testing Conditions and Requirements.....	5
9. 外观 Outside Appearance.....	6
10. 包装、储存及运输 Packing/Storage/Shipment.....	6
11. 安全警告及注意事项 Safety precaution and prohibitions.....	6
12. 贮存 Storage.....	7
13. 保质期限 Guarantee Period of Quality.....	8
14. 电池外形结构及尺寸 Appearance structure and Size of The Battery.....	9

1. 适用范围 Scope

本产品规格书描述了东莞市沃泰通新能源有限公司所生产的二次锂离子电池主要性能指标,用户请务必按照本规格书中的测试和使用方法进行使用,如果有不明之处,请与供方协商解决。

This product specification describes Dongguan Fbtech New Energy co.,Ltd production of lithium-ion rechargeable battery main performance index, please according to the specification of testing and the use of methods were used, if unknown, please and supplier negotiation

2. 产品型号 Model

型号: 32650-5500mAh

Model: 32650-5500mAh

3. 引用标准 Reference standard

本标准参考国标 GB/T18287-2013、UL1642 以及 CE61960 等技术标准规范编制而成。

The standard reference GB/T18287-2013, UL1642 and CE61960 technology standards compiled.

4. 产品规格 Specification

项目 Items	规格 Specification	备注 Remarks
4.1 标称容量 Nominal Capacity	5500mAh	0.2 C ₅ A 放电 0.2 C ₅ A Discharge
4.2 标称电压 Nominal Voltage	3.2V	
4.3 放电终止电压 Discharge Cut-off Voltage	2.0V	0.2 C ₅ A 放电 0.2 C ₅ A Discharge
4.4 充电限制电压 Charge Limited Voltage	3.65±0.03V	0℃~60℃
4.5 标准充电电流 Standard Charge Current	1C ₅ A	0℃~60℃
4.6 标准放电电流 Standard Discharge Current	1 C ₅ A	-10℃~ +60℃
4.7 快速充电电流 Rapid Charge Current	3C ₅ A	0℃~60℃
4.8 快速放电电流 Rapid Discharge Current	3C ₅ A	-10℃~ +60℃
4.9 最大放电电流 Max. Discharge Current	6C ₅ A	终止电压 2.0V Limited Voltage2.0V
4.10 最大脉冲放电电流 (瞬时 ms) (Max. Pulse Discharge Current)	10C ₅ A	瞬时 ms
4.11 内阻 Internal Impedance	≤10mΩ	AC 1kHz 条件下 At AC 1kHz
4.12 重量 Weight	大约 About136g	重量±1g
4.13 电池储存环境温度范围 Storage Temperature Range	≤1 个月 one month	出货电压 (Voltage of shipment) 3.1V~3.4V
	≤3 个月 three months	
	≤12 个月 a year	

5. 电性能测试 (Electrical Characteristics)

项目 Items	测试方法 Test Conditions	标准 Specification
5.1 标准充电 (Standard Charge)	标准充电是指电池芯在环境温度 $20 \pm 5^\circ\text{C}$ 下, 以 $1C_5$ 恒电流充电至电压 3.65V , 恒电压 3.65V 充电至截止电流 $0.05C_5$ (用锂离子电池芯专用充电器, 电压精度 $\pm 0.05\text{V}$), 停止充电, 总充电时间不超过 8 个小时。 (The "Standard Charge" means charging with constant current $1C_5$ to 3.65V , then charging with constant voltage 3.65V to $0.05C_5$ under $20 \pm 5^\circ\text{C}$ charging time will not more than 8h.) (Use Lithium-ion battery charger, which with an accuracy $\pm 0.05\text{V}$.)	
5.2 标称容量 Nominal Capacity	电池芯以标准充电后, 在 $20 \pm 5^\circ\text{C}$ 环境下, 以 $1C_5\text{A}$ 电流放电至终止电压 2.0V , 停止放电。如果没有特别说明, 电池芯充放电间隔时间为 30 分钟。 (The capacity means the discharge capacity of the cell, which is measured with discharge current $1C_5\text{A}$ to cut-off voltage at 2.0V at $20 \pm 5^\circ\text{C}$ rest for 30 minutes after the Standard Charge.)	标称容量 $\geq 5500\text{mAh}$ (Nominal Capacity $\geq 5500\text{mAh}$)
5.2 循环寿命 Cycle Life	电池在 4000 次 70% 放电深度循环后, 再以 $1C_5\text{A}$ 的电流放电至 2.0V 终止电压, 测量其放电容量。 Cell shall be charged 70%SOC at CC mode ($1C_5$, End-of-charge voltage: 3.65V)	$\geq 80\%$ 标称容量 $\geq 80\%$ Nominal Capacity
5.3 贮存特性 (Storage Characteristic)	1 用 $0.2C_5\text{A}$ 电流测量电池芯在 $23 \pm 2^\circ\text{C}$ 的环境下的初始容量并记录, 充入 45% 的电量, 测量电池芯存储前的初始状态, 分别 $20 \pm 5^\circ\text{C}$ 、相对湿度 45%~75% 的环境下贮存 3 个月、6 个月、12 个月, 测量电池芯的最终状态, 然后在 $23 \pm 2^\circ\text{C}$ 的环境温度下以 $0.2C_5\text{A}$ 充放电, 循环 5 次并记录电池芯的放电时间; 5 周循环的最大放电时间作为判断标准。 (Test the cell initial capacity using $0.2C_5$ current at $23 \pm 2^\circ\text{C}$ and record, then charge the cells with 45% capacity, then storage for 3, 6, 12 months respectively at $20 \pm 5^\circ\text{C}$ and relative humidity of 45%~75%, then the cell is cycled for 5 times with charge with $0.2C_5\text{A}$ and discharge with $0.2C_5\text{A}$ at $23 \pm 2^\circ\text{C}$, The maximum discharge capacity (longest discharge time) is recorded.)	0.2C ₅ A 放电时间: 贮存 3 个月的电池芯 $\geq 4.5\text{h}$; 贮存 6 个月的电池芯 $\geq 4.25\text{h}$; 贮存 12 个月的电池芯 $\geq 4\text{h}$ 。 0.2C ₅ A discharge time: After 3 months storage $\geq 4.5\text{hrs}$; After 6 months storage $\geq 4.25\text{hrs}$; After 12 months storage $\geq 4.0\text{hrs}$
	2 电池芯在 $20 \pm 5^\circ\text{C}$ 环境下按 $1C_5\text{A}$ 充放电, 放电容量为 C_1 , 满电电池芯在 $20 \pm 5^\circ\text{C}$ 的温度下储存 28 天后, 在 $20 \pm 5^\circ\text{C}$ 环境下使用 $1C_5\text{A}$ 电流放电, 容量为 C_2 。 (The cell is charged and discharged using $1C_5$ at $20 \pm 5^\circ\text{C}$. The discharge capacity is C_1 . The cell is stored for 28 days in $20 \pm 5^\circ\text{C}$ after fully charged and then is discharged using $1C_5$ at $20 \pm 5^\circ\text{C}$. The capacity is defined as C_2 .)	容量保持率 $C_2/C_1 \geq 90\%$ (Capacity Retention $C_2/C_1 \geq 90\%$)
	3 进行完 C_2 测试的电池芯在 $20 \pm 5^\circ\text{C}$ 环境下按照 $0.2C_5$ 测试恢复容量 (放电容量 C_3)。 (After the test as C_2 , The cell is charged and discharged using $0.2C_5$ at $20 \pm 5^\circ\text{C}$, The discharge capacity is C_3 .)	容量恢复率 $C_3/C_1 \geq 92\%$ (Capacity recoverable ratio $C_3/C_1 \geq 92\%$)

5.4 倍率性能 (Rate Capacity)	1. 在充电后 1 小时内, 以 0.2C ₅ A 电流连续放电至 2.0V 终止电压。 The discharge capacity is measured with 0.2 C ₅ A discharge current and 2.0V cut-off voltage after full charged.	≥100%标称容量 ≥100%Nominal Capacity
	2. 在充电后 1 小时内, 以 0.5C ₅ A 电流连续放电至 2.0V 终止电压。 The discharge capacity is measured with 0.5 C ₅ A discharge current and 2.0V cut-off voltage after full charged.	0.5C/1C=96%
	3. 在充电后 1 小时内, 以 1C ₅ A 电流连续放电至 2.0V 终止电压。 The discharge capacity is measured with 1 C ₅ A discharge current and 2.0V cut-off voltage after full charged.	1C/1C=93%
	4. 在充电后 1 小时内, 以 6C ₅ A 电流连续放电至 2.0V 终止电压。 The discharge capacity is measured with 3 C ₅ A discharge current and 2.0V cut-off voltage after full charged.	6C/1C=85%

6 环境适应性 Environment Characteristics.

项 目 Items	测试方法 Test Conditions	标 准 Specification
6.1 温度性能 Temperature Performance	电池芯按 5.1 规定充电, 按 1C ₅ A 的电流放电至 2.0V。电池芯必需先在不同的试验温度中放置 4 个小时后放电, 百分比按放电容量比最小容量计算。 (Cells shall be charged according to 5.1 and discharged at 0.2C ₅ A to 2.0 V. Cells shall be stored for 4 hours at the test temperature prior to discharging and then shall be discharged at the test temperature, The percentage shall be calculated using discharging capacity compared to the minimum capacity.	不泄漏、无外观不良 No leakage, No Appearance defect
		-20°C/25°C≥70%
		Stored at 55°C for 7 days .After standing for 5h,discharged cell per 4.6 /25°C≥98%
6.2 恒定湿热 Constant Temperature and Humidity	在 23±2°C 条件下, 电池芯按 0.2C ₅ A 充电结束后, 放入 40±2°C, 湿度 90~95% 的恒温恒湿箱内 48h, 取出电池芯常温搁置 2h, 以 0.2C ₅ A 放电至 2.0V。 (Under the temperature of 23±2°C, after charging the cell with 0.2C ₅ A ,then put the cell into the constant temperature and humidity oven with 40±2°C and 90~95% for 48h, then store the cells at RT for 2hrs, and discharge the cells with 0.2C ₅ A to 2.0 volts.)	电池芯应无变形、无泄漏、无锈蚀、无起火、无爆炸, 放电时间≥3 小时 (The cell should be no deformation, no rust, no leakage, no fire, no smoking and no explosion. Discharge time ≥3h)
6.3 自由跌落 测试 (Free Fall Test)	将满充电的电池芯重复 3 次由高度为 1000mm (电池芯最低点) 的位置自由跌落到混凝土板上; 在跌落时应在随机的方向都有一个冲击力, 测试完成后电池芯放置 1h, 然后目视检查; (The fully charged cell is dropped three times from a height of 1000 mm (the lowest point of the cell) onto a concrete floor. The cells or batteries are dropped so as to obtain impacts in random orientations. After the test, the cell shall be put on rest for a minimum of one hour and then a visual inspection shall be performed.)	不爆炸、不起火、不冒烟, 开路电压应不低于 90% 的初始电压 (No explosion, No fire, No smoke. The OCV after the test no less than 90% before free-fall test.)

6.4 振动测试 (Vibration Test)	将满充电后的电池芯固定在振动台上, 沿 X、Y、Z 三个方向各振动 90~100 分钟, 振幅 0.8mm, 振动频率为 10Hz~55Hz, 每分钟变化 1Hz, 在测试完成后电池芯回复到原位。样品在测试结束后观察 6 小时, 并检查测试前后电池芯的重量变化。 (A full-charged cell is to be subjected to simple harmonic motion with amplitude of 0.8mm total maximum excursion. The frequency is to be varied at the rate of 1 hertz per minute between 10 and 55 hertz. After the test is completed, And the cell returned to the starting position. The cell shall be vibrated for 90~100 minutes per axis of XYZ axes. The samples should be observed for 6 hours after the test, and also check the weight loss of cells before and after the test.)	不爆炸、不起火、不冒烟、不泄漏, 重量损失 $\leq 0.1\%$ (Not explosion, No fire, No leakage, Mass loss $\leq 0.1\%$)
6.5 挤压测试 (Crush Test)	将满充电的池芯放在可移动的平面间进行挤压, 其压力通过一个液压缸进行施压, 施加的压力为 $13 \pm 1\text{KN}$, 一旦达到压力后或电芯电压下降至原始电压的 $1/3$ 或与原尺寸相比发生了 10% 的变形, 即可释放压 (无论哪种情况发生)。(A full charged cell is to be crushed between two flat surfaces. The force for the crushing is applied by a hydraulic ram exerting a force of $13 \pm 1\text{KN}$. Once the maximum force has been applied, or an abrupt voltage drop of one- third of the original voltage has been obtained, or 10% of deformation has occurred compared to the initial dimension, the force is released)	不爆炸、不起火 (No explosion, No fire)
6.6 机械冲击测试 (Shock Test)	将满充电的电池芯在两个轴向方向进行测试, 每个轴向有正反两个方向。在最初的 3 毫秒内最小的平均加速度为 75g , 峰值加速度介于 125g 和 175g 之间。样品在测试结束后需观察 6 小时, 并检查测试前后电池芯的重量变化。测试温度在 $20 \pm 5^\circ\text{C}$ 。 (The full charged cell has only two axes of symmetry in which case only two directions shall be tested. Each shock is to be applied in a direction normal to the face of the cell. For each shock the cell is to be accelerated in such a manner that during the initial 3 milliseconds the minimum average acceleration is 75g . The peak acceleration shall be between 125 and 175g . The samples should be observed for 6 hours after the test, and also check the weight loss of cells before and after the test. Cells shall be tested at a temperature of $20 \pm 5^\circ\text{C}$.)	不爆炸、不起火、不泄漏, 重量损失比 $\leq 0.1\%$ (No explosion, No fire, No leakage. Mass loss $\leq 0.1\%$)
6.7 高空低压模拟测试 (Altitude Simulation Test)	将充满电的电池芯放入真空箱中, 逐渐抽真空至气压小于或等于 11.6KPa , 并在此气压下保存 6H, 测试温度为 $20 \pm 3^\circ\text{C}$ 。 (The full-charged cells are to be stored for 6 hours at an absolute pressure of 11.6KPa and a temperature of 20 ± 3 .)	不爆炸、不起火、不泄漏, 重量损失比 $\leq 0.1\%$ (No explosion, No fire, No leakage. Mass loss $\leq 0.1\%$)

7. 安全性能 Safety Characteristics

项 目 Items	测试方法 Test Conditions	标 准 Specification
7.1 外部短路 (Short Circuit)	分别在 $20 \pm 5^\circ\text{C}$ 和 $55 \pm 5^\circ\text{C}$ 的环境温度下依次用内阻为 $80 \pm 20\text{m}\Omega$ 的铜线连接电池芯的正负极持续放电直至发生爆炸、起火或至电压小于 0.2V , 电池芯表面温度恢复到环境温度 $\pm 10^\circ\text{C}$ 以内。电池芯要求: 充满电的新电池芯。 (Each test sample cell is to be short-circuited by connecting the positive and negative terminals of the cell with a Cu wire having a maximum resistance load of $80 \pm 20\text{m}\Omega$. The sample is to discharge until a fire or	电池应不起火、不爆炸; 温度 $< 150^\circ\text{C}$ 。 No fire, No explosion; Max.Temp,of battery surface should not exceed 150°C

	exposition is obtained, or until it has reached a completely discharge state of less than 0.2V and the sample case temperature has returned to ± 10 of the ambient temperature. Tests are to $^{\circ}\text{C}$ be conducted at $20\pm 5^{\circ}\text{C}$ and $55\pm 5^{\circ}\text{C}$. Cell Condition: Fresh, Fully charged cell.)	
7.2 过充电 Over-charge Characteristics	<p>充电后的电池，用 $3\text{C}_5\text{A}$ 电流和 4.8V 的恒定电压充电 8 小时。</p> <p>The battery is charged at a $3\text{C}_5\text{A}$ constant current with a voltage limit of 4.8V for 8 hours after fully charged</p>	<p>电池应不起火、不爆炸；温度 $< 150^{\circ}\text{C}$。</p> <p>No fire, No explosion; Max.Temp.of battery surface should not exceed 150°C.</p>
7.3 过放电 Over Discharge	<p>标准充电后，电池芯以 $0.2\text{C}_5\text{A}$ 恒电流放电至 2.0V，用一根内阻小于 30Ω 的导线连接电池芯正负极 24 小时。</p> <p>(After standard charge.Cells are discharged at constant Current of $0.2\text{C}_5\text{A}$ to 2.0V, and the positive and negative terminal is connected by a 30Ω wire for 24 hours. Cell Condition: Fresh, Fully charged cell.)</p>	<p>不爆炸、不起火</p> <p>(No explosion, No fire)</p>
7.4 热冲击 Hot oven Characteristics	<p>将电池充电后，放置于热箱中，温度以 $(5^{\circ}\text{C}\pm 2^{\circ}\text{C})/\text{min}$ 的速率升至 $130^{\circ}\text{C}\pm 2^{\circ}\text{C}$ 并保温 30min。</p> <p>The fully charged battery is placed the battery in the hot box, then rose to $130^{\circ}\text{C}\pm 2^{\circ}\text{C}$ in the temperature to $5^{\circ}\text{C}\pm 2^{\circ}\text{C}/\text{min}$ rate, insulation 30min.</p>	<p>电池应不起火、不爆炸。</p> <p>No fire, No explosion</p>
7.5 强制放电 (Forced Discharge)	<p>电池芯以 $0.2\text{C}_5\text{A}$ 进行放电至 2.0V，然后以 $1.0\text{C}_5\text{A}$ 的电流对电池进行反向充电，要求充电时间不低于 90min。</p> <p>(The cell shall be discharge to 2.0V with the current $0.2\text{C}_5\text{A}$, then the discharge cell is subjected to reverse charge at $1.0\text{C}_5\text{A}$ for not less than 90minutes.)</p>	<p>不爆炸、不起火</p> <p>(No explosion, No fire)</p>
7.6 高温储存 (High Temperature Storage Test)	<p>将电池芯放置在 $80\pm 2^{\circ}\text{C}$ 自然对流烘箱中 7 小时后，取出待返回到室温，目测电池芯要求：充满电的新电池芯。</p> <p>(Put cell into the 80°C box and keep the cell in the box for 7 hours after it be charged according to 6.1, and then take it out. Cell Condition: Fresh, Fully charged cell.)</p>	<p>不爆炸、不起火</p> <p>(No explosion, No fire)</p>
7.7 冷热循环性能测试 (Thermal-cold Cycling Performance Test)	<p>电池芯在标准充电后，在环境温度 $75\pm 2^{\circ}\text{C}$ 条件下开路放置 6 小时，然后 -40°C 条件下开路放置 6 小时，温度转换时间小于 30 分钟，温度循环 10 次，最后室温条件下放置 24h，观察电池芯外观变化。</p> <p>(The full-charged cell is placed in $75\pm 2^{\circ}\text{C}$ for 6h, and then put the Cell in -40°C for 6h; change temperature time $< 30\text{min}$, then repeat it for 10 cycles. Finally the cell is placed in room temperature for 24h. Watch the appearance of cell.)</p>	<p>不起火、不爆炸、不冒烟，试验后开路电压应不低于试验前的 90%，质量损失 $\leq 0.1\%$</p> <p>(No explosion, No fire, No smoke, Open circuit voltage changed not less than 90%, mass loss limit: $\leq 0.1\%$)</p>
7.8 重物撞击 (Impact Test)	<p>用一条直径为 $15.8\pm 0.1\text{mm}$ 的圆棒放置在电池芯中央，将重量为 $9.1\pm 0.46\text{Kg}$ 的重锤从 $610\pm 25\text{mm}$ 的高度垂直落在电池芯长度的中心位置。电池芯要求：充满电的新电池芯。</p> <p>(A test sample cell is to be placed on a flat surface. A $15.8\pm 0.1\text{mm}$ diameter bar is to be placed across the center of the sample. A $9.1\text{Kg}\pm 0.46\text{Kg}$ mass is to be dropped from the height of $610\pm 25\text{mm}$ to the center of the cell vertically. Cell Condition: Fresh, Fully charged cell.)</p>	<p>不爆炸、不起火</p> <p>(No explosion, No fire)</p>

8. 标准测试条件 Standard Testing Conditions and Requirements

8.1 标准测试条件和要求 Standard Testing Conditions and Requirements

测试的电池芯是出厂时间不超过 3 个月的新电池芯，且电池芯未进行过五次以上充放电循环。除

非其它特殊要求，本产品规格书规定的测试条件为：温度 15~35℃，相对湿度 45%~85%。

Test should be conducted with new cells within three months after shipment from our factory and cells shall not be cycled more than five times before test. Unless there is special requirement, test shall be done under temperature of 15~35℃ and relative humidity of 45%~85%.

8.2 测量设备及仪表 Measurement Equipment and Instrumentation

8.2.1 尺寸测量 Measurement Tool

用精度为 0.01mm 的卡尺或更高精度的工具测量尺寸，量程范围 0~100mm。

With a precision of 0.01mm caliper or higher precision instruments for measuring size, range 0~100mm.

8.2.2 电压测量 Measurement Voltage

用精度为 0.01V 的电压表测量电压，量程范围 0~20V。

With a precision of 0.01V voltage meter measuring voltage, range 0~20V.

8.2.3 电流测量 Measurement Current

用精度为当前电流±0.4%的电流表测量电流，量程范围 0~10A。

With a precision of± 0.4% current Ammeter to measure the current, range 0~10A.

8.2.4 内阻测量 Measurement Impedance

用一个 1KHz 的正弦交变电流内阻仪测量内阻。

The impedance is measured with 1KHz sinusoidal alternating current resistance instrument.

9. 外观 Outside Appearance

不允许有任何影响电芯性能的外观缺陷，如漏液、生锈、变形、严重炸火等。

There should not be any appearance defect such as leakage, rust, deformation, severe blow fire effect on cell performance.

10. 包装、储存及运输 Packing/Storage/Shipment

10.1 电池装运前的检查 Pre shipment inspection

对于所有电池，在装运前需检查其电压、内阻与保护电路的功能。

The battery should be checked the voltage, resistance and the function of protective circuit before shipment.

10.2 包装与运输电池 Packing and Shipping

10.2.1 当电池需要再运输以便在工厂装配时，要特别注意包装，以避免运输时产生应力。沃泰通公司建议再运输时，使用同沃泰通公司运输时同样的包装。即使打开了包装，当再运输时，使用沃泰通公司同样的部件和材料进行再包装。

The battery should be transported to the factory assembly, to pay special attention to the packing, in order to avoid transport stress. We suggest to use the same packaging when the battery be transported. Even the package is opened, please pack with the components and materials as same as WoTaiTong,Ltd.

10.2.2 电池应在半荷电状态包装成箱进行运输，在运输过程中，防止剧烈振动、冲击、挤压，防止日晒雨淋，应使用汽车、火车、轮船、飞机等交通工具运输。

The battery should be in a half state of charge packaging boxes for transport, in the transport process, prevent severe vibration, shock, extrusion, prevent the sun and rain, should be in automobile, train, ship, airplane and other forms.

10.3 电池异常 Abnormal Condition

不要使用由于运输中应力、跌落、短路或其它原因被损害并发出电解液异味的异常电池。

Do not use the battery when it's smell like abnormal cell electrolyte because of transport stress, sag, short circuit or any other.

11. 安全警告及注意事项 Safety precaution and prohibitions

为了防止电芯出现泄漏、发热、着火、性能降低或寿命下降、爆炸等事故，请按如下操作规定正常使用电池，并遵守防范事项。

In order to prevent battery leakage, heating, fire, reduced performance or life drops, explosion and other accidents, please do the following provisions of the normal use of battery, and compliance with preventive matters.

11.1 充电 Charging

11.1.1 充电电流 Charging Current

充电电流不得超过本标准书中规定的最大充电电流。使用高于推荐值电流充电将可能引起电池的充放电性能、机械性能和安全性能的问题，并可能会导致发热或泄漏。

Charging current should be less than maximum charge current specified in the Product Specification. Charging with higher current than recommended value may cause damage to cell electrical, mechanical and safety performance and could lead to heat generation or leakage.

11.1.2 充电电压 Charging Voltage

充电电压不得超过本标准书中规定的额定电压（3.65V/电池）。3.65V 为充电电压最高极限，充电器的设计应满足此条件。电池电压高于额定电压值时，将可能引起电池的充放电性能、机械性能和安全性能的问题，可能会导致发热、泄漏或爆炸。

Charging shall be done by voltage less than that specified in the Product Specification (3.65V/cell). Charging beyond 3.65V, which is the absolute maximum voltage, must be strictly prohibited. The charger shall be designed to comply with this condition. It is very dangerous that charging with higher voltage than maximum voltage may cause damage to the cell electrical, mechanical safety performance and could lead to heat generation, leakage or explosion.

11.1.3 充电温度 Charging Temperature

电池必须在 0°C~60°C 的环境温度范围内进行充电。

The cell shall be charged within 0°C~60°C range in the Product Specification.

11.1.4 禁止反向充电

正确连接电池的正负极，严禁反向充电。若电池正负极接反，将无法对电池进行充电。同时，反向充电会降低电池的充放电性能、安全性，并会导致发热、泄漏或爆炸。

Reverse charging is prohibited. The cell shall be connected correctly. The polarity has to be confirmed before wiring, In case of the cell is connected improperly, the cell cannot be charged. Simultaneously, the reverse charging may cause damaging to the cell which may lead to degradation of cell performance and damage the cell safety, and could cause heat generation, leakage or explosion.

11.2 放电 Discharging

11.2.1 放电电流 Discharging Current

放电电流不得超过本标准书规定的最大放电电流，大电流放电会导致电池容量剧减并导致过热。

The cell shall be discharged at less than the maximum discharge current specified in the Product Specification. High discharging current may reduce the discharging capacity significantly or cause over-heat.

11.2.2 放电温度 Discharging Temperature

电池必须在-10°C~60°C 的环境温度范围内进行放电。

The cell shall be discharged within -10°C~60°C range specified in the Product Specification.

11.2.3 过放电 Over-Discharging

需要注意的是，在电池长期未使用期间，它可能会用其它自放电特性而处于某种过放电状态。为防止放电的发生，电芯应定期充电，将其电压维持在 3.0V 至 3.45V 之间。过放电会导致电芯性能、电池功能的丧失。充电器应有装置来防止电池放电至低于本标准书规定的截止电压。此外，充

电器还应有装置以防止重复充电。

It should be noted that the cell would be at over-discharged state by its self-discharge characteristics in case the cell is not used for long time. In order to prevent over-discharging, the cell shall be charged periodically to maintain between 3.0V and 3.45V. Over-discharging may causes loss of cell performance, characteristics, or battery functions. The charger shall be equipped with a device to prevent further discharging exceeding a cut-off voyage specified in the Product Specification. Also the charger shall be equipped with a device to control the recharging procedures.

11.3 异常处理 Exception Handling

如果电芯出现被破坏、变形、电解液泄漏或闻到有电解液味道以及其他不正常现象，请不要再使用该电芯；此外，泄漏电解液的电芯应远离火源，避免引起爆炸。

Do not use the cell if you find it in unusual conditions such as distortion, leakage (or odors).The cell should be kept away from fire to avoid an explosion.

12. 贮存 Storage

12.1 贮存温度与湿度 Storage temperature and humidity

电池应贮存在环境温度范围为-20°C~+35°C，相对湿度在 25~75%的清洁、干燥、通风的室内，应避免与腐蚀性物质接触，应远离火源及热源。

The cell shall be storied at temperature range of -20 °C~ +35 °C, relative humidity of 25~75%, clearing, drying, ventilated, and kept away from corrosive substances and fire.

12.2 长时间储存 Long Time Storage

如果要长时间贮存，电池应在温度范围-20°C~+25°C、低潮湿和无腐蚀性气体环境中贮存。超过三个月时，应对电池进行一次完全充放电循环，再将电池充电约 3.3V/电池的条件下贮存。

If the battery is stored for a long time, the battery should be conducted a cycle of charge and discharge, and the voltage should be about 3.3V and the battery is to be stored at temperature range of -20 °C~ +25 °C, low moisture and corrosive gases environment.

13. 保质期限 Guarantee Period of Quality

电池保质期为打码出厂后的 2 年。若电池在此期间内出现异常情况，但必须是由于明显的制造工艺方面的问题，且在电池没有被异常使用的情况下,沃泰通才免费更换新电池。

The guarantee period of quality extend for one year after code. WoTaiTong,Ltd would replace battery which due to the manufacturing problems and it is not abnormal use, if the battery appears during the abnormal situation.

14. 电池外形结构及尺寸 Appearance structure and Size of The Battery

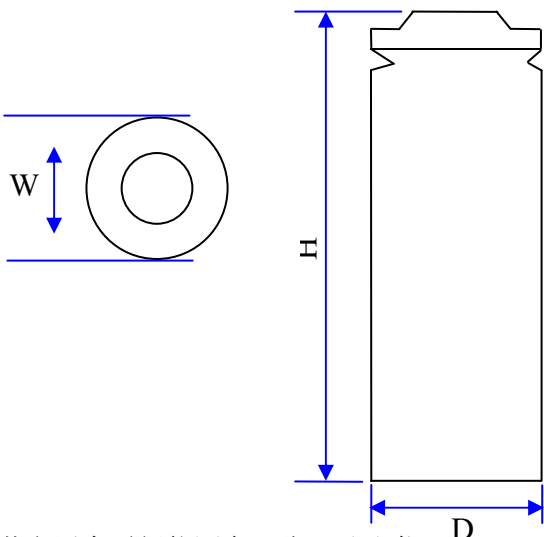

项目 Items	尺寸 Size(mm)	公差 Tolerance(mm)
铆钉宽度 Width	15.92	+0.1
		-0.1
电池高度 Height	70.5	+0.4
		-0.2
电池直径 Diameter	31.98	+0.3
		-0.3

15.特征性曲线图

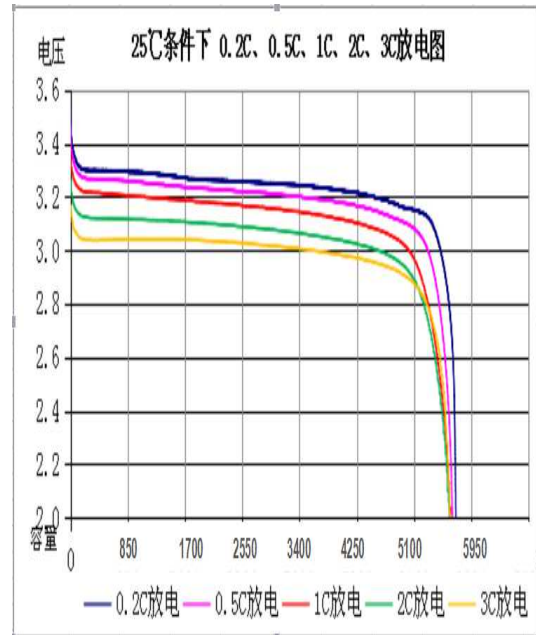
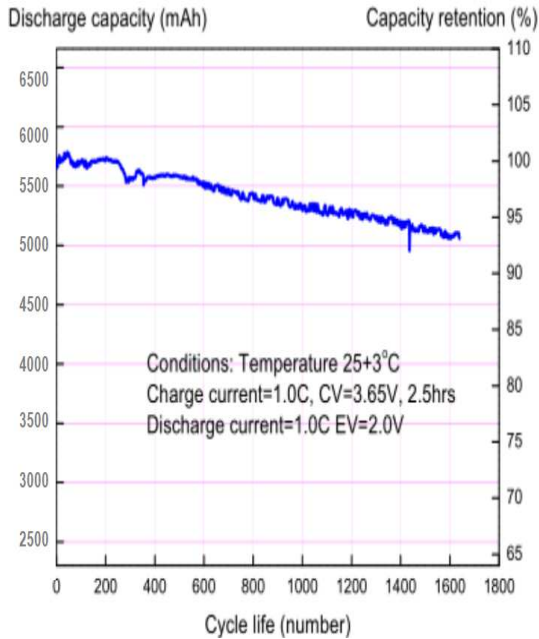

充电曲线图
charge curve

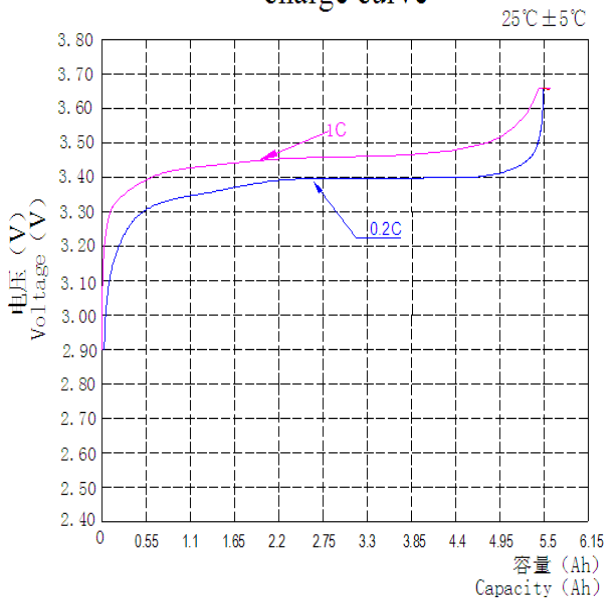

放电曲线图
Diploid discharge curve

