



昌勛股份有限公司  
DR.POWER CORPORATION  
零件規格書 / 承認書  
SPECIFICATION FOR APPROVAL

CUSTOMER : \_\_\_\_\_

DESCRIPTION : Battery Pack Charger 座充(單槽)

MODEL : JW2024充電座

CUSTOMER PART NO : \_\_\_\_\_

**APPROVED SIGNATURES**

			
---	--	--	--

Rev	Date	Description	Designed	Checked	Approved
A	23/10/17	Release		Eddie	

臺北市北投區吉利街 131 號 2 樓

2F, NO. 131, JILI ST., PEITOU, TAIPEI, TAIWAN, R.O.C.

TEL : 886-2-2827-0158 · FAX : 886-2-2827-0348

# Product Specification

Model Name : JW2024

Parts Number :

Issue Date	Revision	Modified Content	Approval
2022.9.15	A	Initial Release	David

# 1.Scope

This specification is a charger only for DR2024 series product lithium-ion battery pack.

# 2.Application

- Lithium-ion battery pack.

# 3.Specification

No.	Item	Specification	Remark
1	Support Battery Cells	4S	
2	Charge Voltage	$16.8 \pm 0.3V$	
3	Charge Current	$3.0 \pm 0.2A$	
4	Charge Current Termination	$300 \pm 10mA$	
5	Recharger Voltage	$\leq 16.4 \pm 0.1V$	
6	Pre-charge Voltage	$\leq 12.3 \pm 0.26V$	
7	Pre-charge Current	$300 \pm 10mA$	
8	Input voltage range	19-24V	
9	Operating Temperature	0~45°C	

# 4. Safety Protection

No.	Item	Specification	Remark
1	Input over voltage	32V	
3	Battery present detection	Yes / No	
4	Charge safety timer	560±10min	
5	Charge Over Current	$4.8 \pm 0.3A$	
6	Battery short	20A / 1us	
7	Battery over voltage	$17.4 \pm 0.3V$	
8	IC Thermal shutdown	145°C	

## 5.LED indicator Status

No.	Description	Color	Remark
1	Charging	Amber	
2	Charge Complete	Green	
3	Battery Fault	Flash Red	

## 6.Pin define

Pin No.	Pin name	Description	Remark
1	BAT+	Postive	
2	SMBC	Battery SMBus Clock	
3	SMBD	Battery SMBus Data	
4	ID	Battery ID Detection	
5	BAT-	Negative	

# 7.Schematic

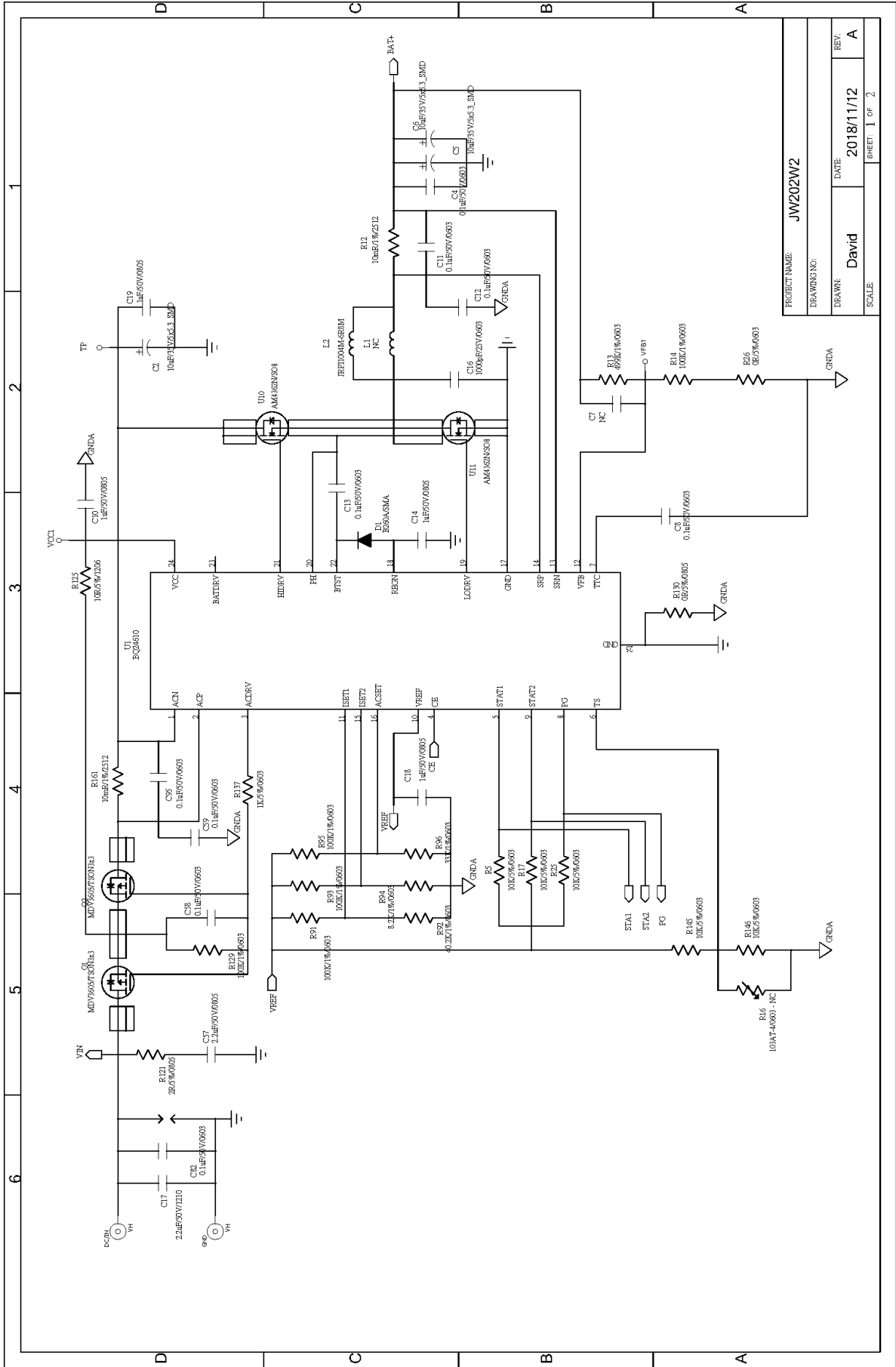

MARK 記號	REVISIONS 變更內容	SIGN 修改	DATE 日期

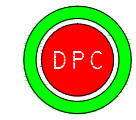
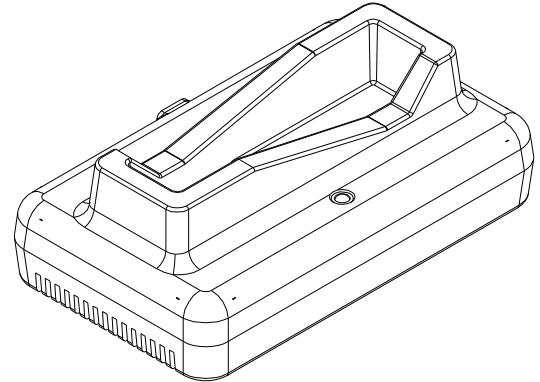
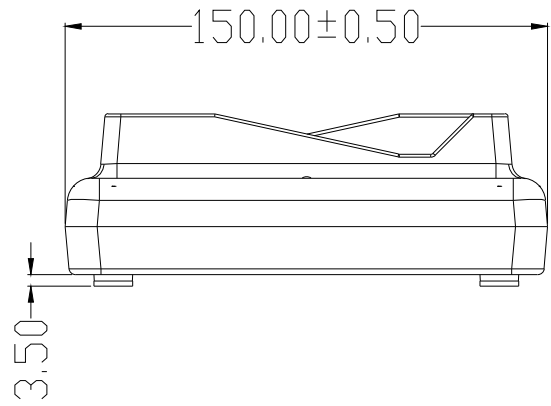
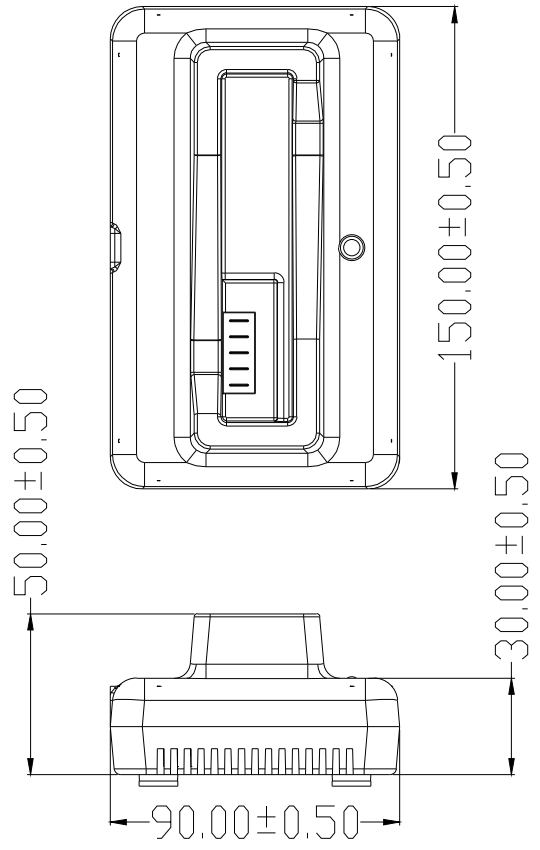

昌勛股份有限公司  
DR. POWER CORPORATION

DIMENSIONAL TOLERANCES

<30	: ±0.25	DECIMALS	UP~100	: ±0.2	UP~600	: ±1.5
<30~100	: ±0.35	X	100~150	: ±0.25	600~900	: ±2.4
>100~300	: ±0.5	X.X	150~200	: ±0.3	900~OVER	: ±3.1
	: ±0.6	X.XX	200~250	: ±0.35		
HOLES	: ±0.05	ANGLES: ±0.5°	250~300	: ±0.4		
ABOVE 300			300~350	: ±0.45		

核准	APPROVED		
審核	CHECKED		
設計	DESIGN	Winyi	2023/06/14
製圖	DRAWN	Winyi	2023/06/14
單位	MM	比例	1:1
UNIT		SCALE	

機型	MODEL	DR-2024-CHARGER	
材質	MATERIAL		
名稱	NAME	OUTLINE	
料號	P/N:		